



Republic of the Philippines
 Department of Agriculture
AGRICULTURAL TRAINING INSTITUTE
REGIONAL TRAINING CENTER 1
 Regional Training Center: Tebag East, Sta. Barbara, Pangasinan, Tel. No. (075) 523-2266
 Satellite Training Center: Erby, Tabug, Batac City, Ilocos Norte, Tel. No. (077) 600-1096
 Email Address: rtc1.doc@ati.da.gov.ph;
 Website: www.ati2.da.gov.ph/ati-1; www.extension.gov.ph

Project : **REPAIR AND REHABILITATION OF ATI-RTC 1 FACILITIES**
 Project No. : **2024-10-0565**
 Location : **ATI-RTC 1, Tebag East, Sta. Barbara, Pangasinan**

BILL OF QUANTITIES

Stock/ Property No.	Item No.	Item Description	%	Unit	Quantity	Direct Cost					Total Mark-Up		5% VAT	Total Cost
						Material	Labor	Equipment	Unit Cost	Total	%	Value		
8	D	FORMWORKS												
	1	Formworks		ls	1									
	E	PAINTING WORKS												
	1	Painting works		sq.m	9.41									
	F	MISCELLANEOUS WORKS												
	1	Mobilization/Demobilization		ls	1.00									
	2	Clearing and hauling		ls	1.00									
	SUB-TOTAL													
	TOTAL													

Prepared by:
ENGR. MARIEL A. DE VERA
 Engineer I

Reviewed by:
AMOR JOYCE M. MARCELO, CPA
 AFU Unit Head

Approved by:
JAYVEE BRYAN G. CARILLO, Ph.D.
 OIC-Center Director

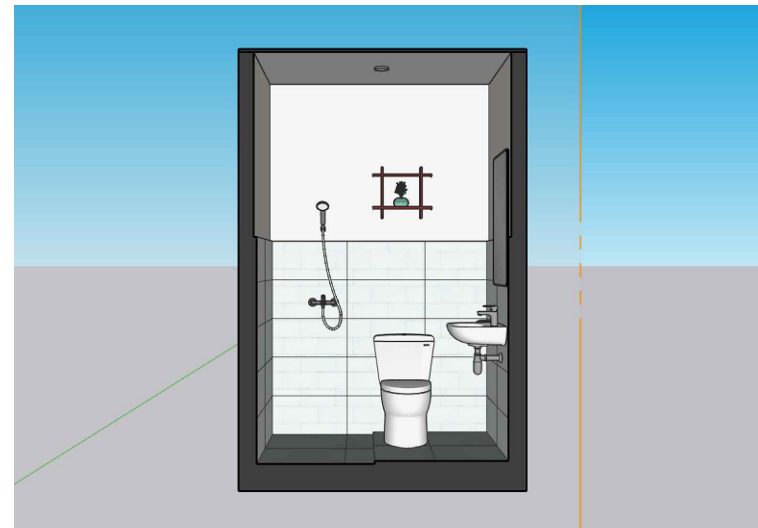
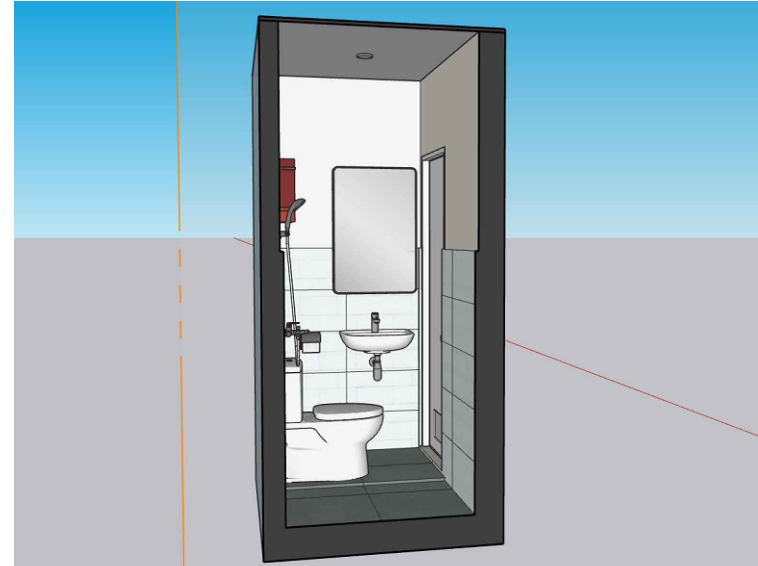
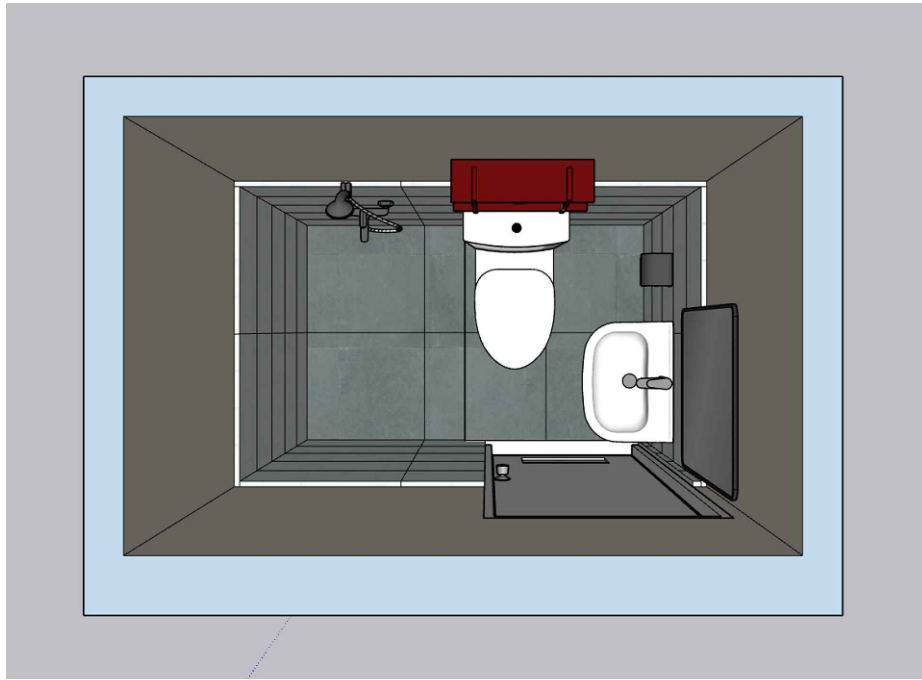

P E R S P E C T I V E
 SCALE _____ NTS

PREPARED BY:

APPROVED BY:

PROJECT NAME:

REPAIR OF DORMITORY ROOMS 1, 2, 3, 5, 8,
9, & 10 (COMFORT ROOM)

SHEET CONTENT:

PERSPECTIVE

SCALE: AS SHOWN

DATE: JUNE 21, 2024

SHEET NO.: 1/4

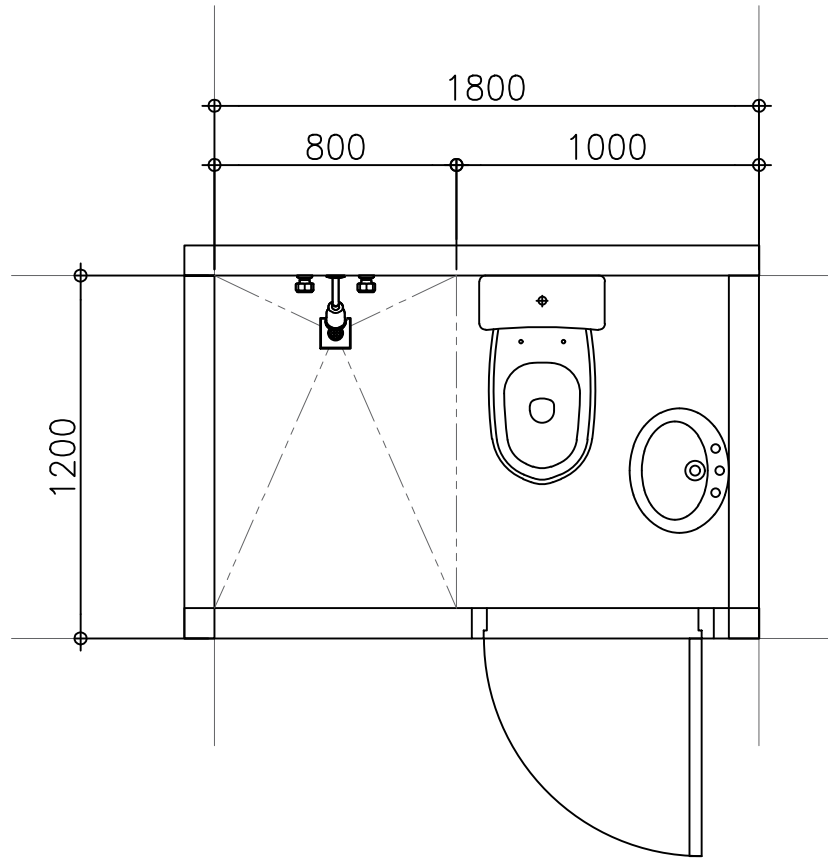

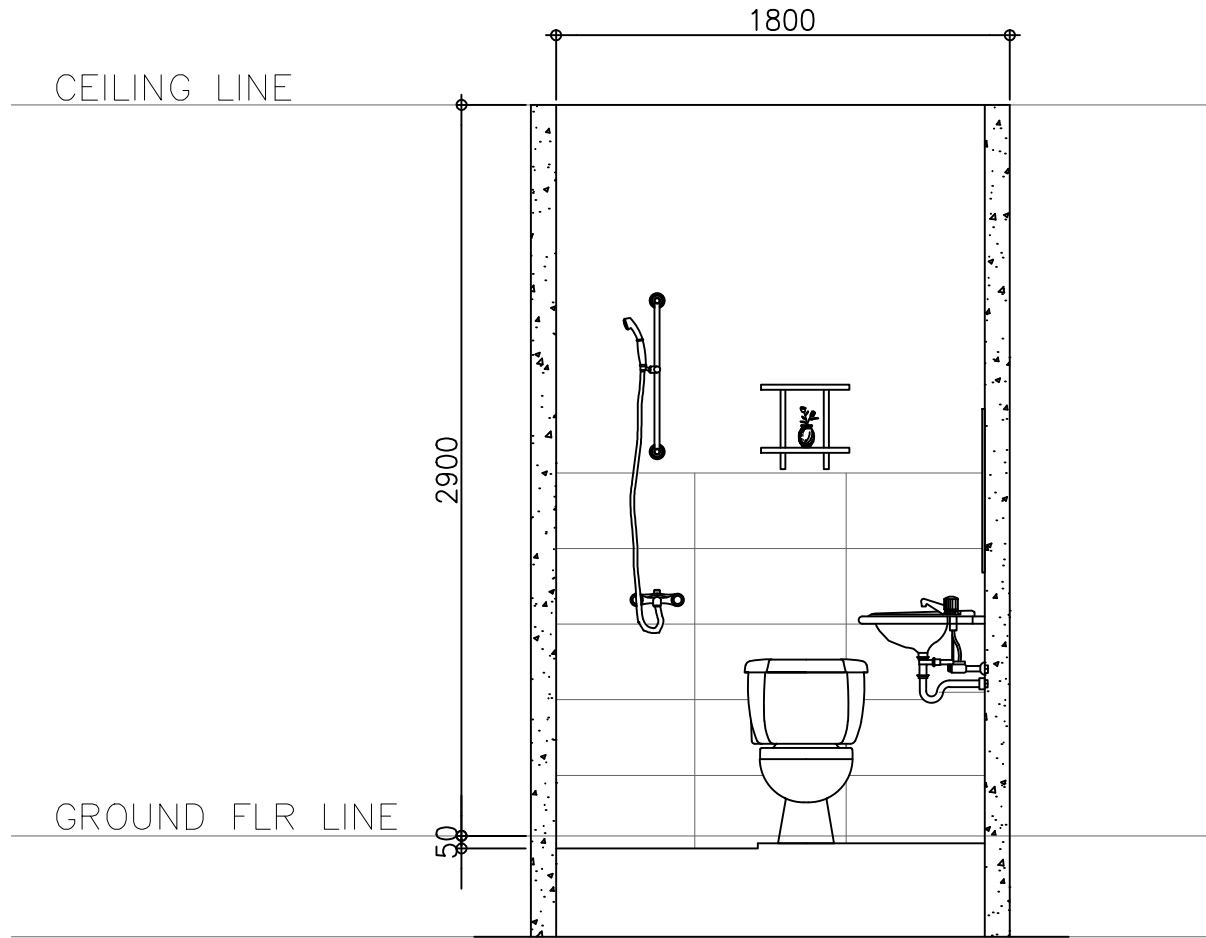

DORM T&B FLOOR PLAN
 SCALE NTS

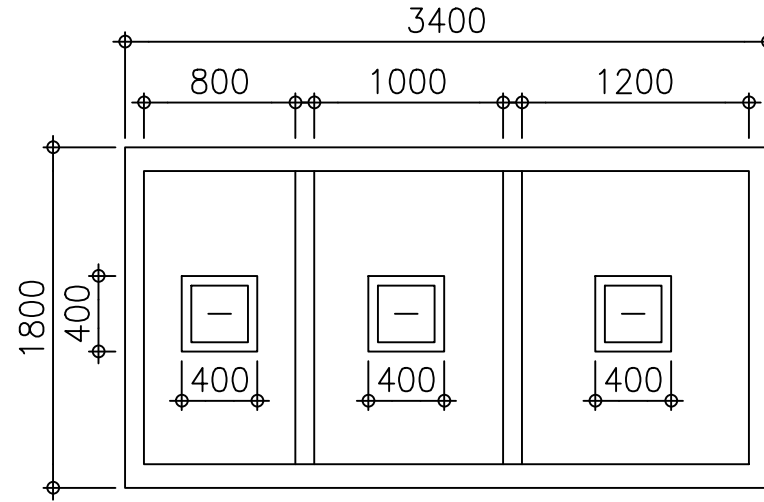

DORM T&B ELEVATION
 SCALE NTS

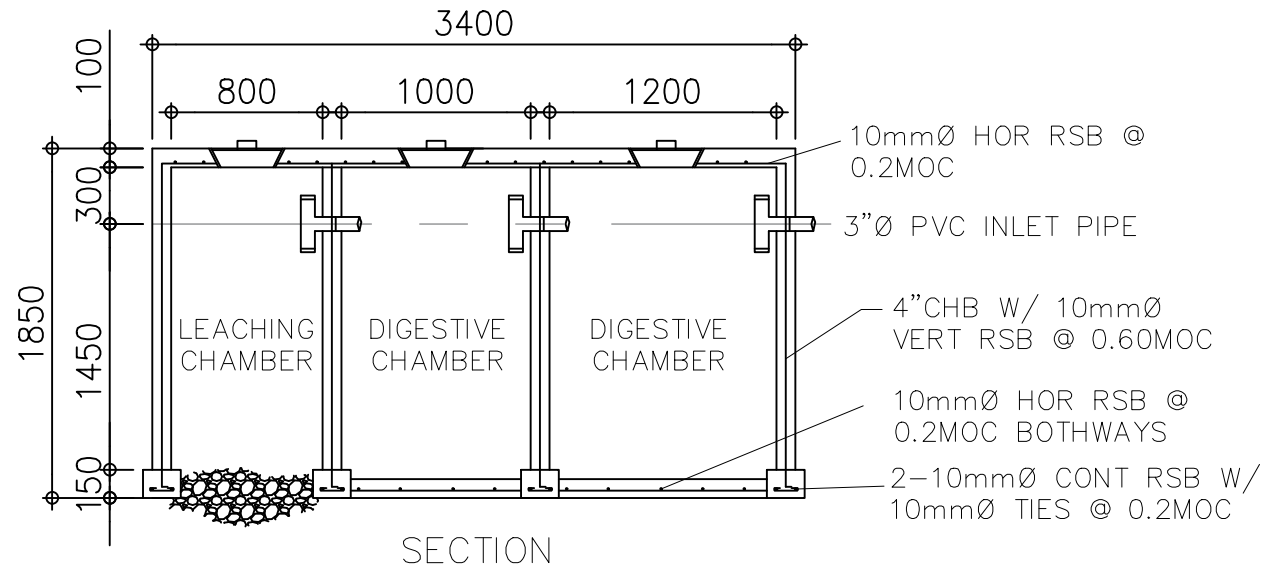

PLAN



SECTION



SEPTIC TANK DETAILS

SCALE

NTS

10mmØ HOR RSB @ 0.2MOC

3"Ø PVC INLET PIPE

4"CHB W/ 10mmØ VERT RSB @ 0.60MOC

10mmØ HOR RSB @ 0.2MOC BOTHWAYS

2-10mmØ CONT RSB W/ 10mmØ TIES @ 0.2MOC

LEACHING CHAMBER

DIGESTIVE CHAMBER

DIGESTIVE CHAMBER

PREPARED BY:

APPROVED BY:

PROJECT NAME:

REPAIR OF DORMITORY ROOMS 1, 2, 3, 5, 8, 9, & 10 (COMFORT ROOM)

ATI-RTC1, TEBAG EAST, STA. BARBARA, PANGASINAN

SHEET CONTENT:

SEPTIC TANK DETAILS

SCALE: AS SHOWN

DATE: JUNE 21, 2024

SHEET NO.: 4/4

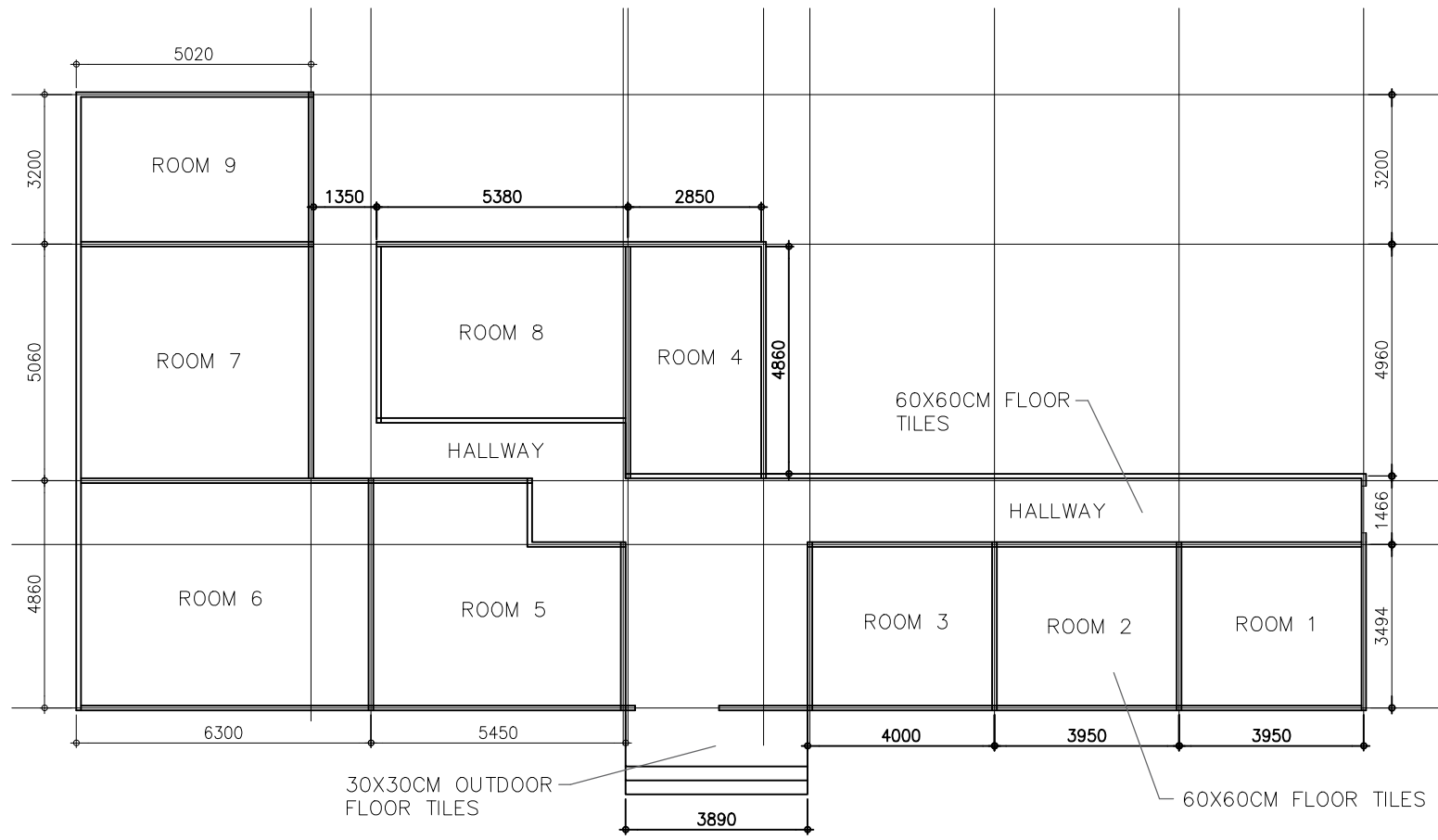

DORMITORY FLOOR PLAN
 SCALE 1:150

 <p>Department of Agriculture Republic of the Philippines Department of Agriculture AGRICULTURAL TRAINING INSTITUTE REGIONAL TRAINING CENTER 1 Regional Training Center, Tebag East, Sta. Barbara, Pangasinan, Tel. No. (075) 522-2265 Satellite Training Center, Dagupan, Ilocos City, Ilocos Norte, Tel. No. (077) 804-1268 Email Address: rti1@agrar.gov.ph Website: www.ati-agrar.gov.ph</p>	PREPARED BY:	APPROVED BY:	PROJECT NAME:	SHEET CONTENT:	SCALE: AS SHOWN
			TILING WORKS ON HALLWAY AND DORM ROOMS 1-10	DORMITORY FLOOR PLAN	DATE: JULY 24, 2024
			ATI-RTC1, TEBAG EAST, STA. BARBARA, PANGASINAN		SHEET NO.: 1/1

COTTAGE - ATTIC STAIR LANDING		
Installation of Fixed Glass with Sliding Glass Door (WHITE)		
Function	Height (m)	Width (m)
D1	2.25	3.8
COTTAGE - ATTIC		
Installation of Sliding Glass Partition (WHITE)		
Attic	Height (m)	Width (m)
Partition	1.65	4.2
BIG HALL		
Installation of Double Panel Glass Door & Frame (WHITE)		
	Height (m)	Width (m)
D1	2.15	1.68
4H-HUB		
Change of Double Panel Frame (WHITE)		
	Height (m)	Width (m)
D1	2.1	1.6

ISS		
Change of Single Panel Frame (WHITE)		
	Height (m)	Width (m)
D1	2.1	0.9
ADMIN/SMALL HALL		
Change of Double Panel Frame (WHITE)		
	Height (m)	Width (m)
D1	2.17	2
PAS		
Change of Single Panel Frame (WHITE)		
	Height (m)	Width (m)
D1	2.1	0.9



SCHEDULE OF DOORS AND WINDOWS
 SCALE _____ NTS



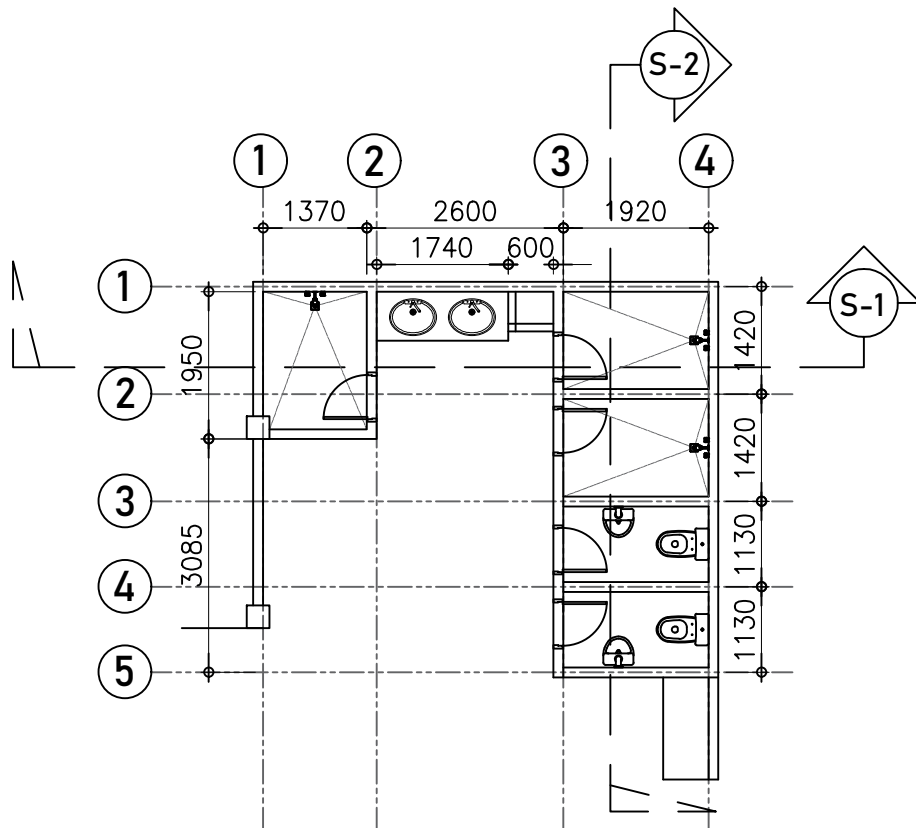

P E R S P E C T I V E
 SCALE _____ NTS

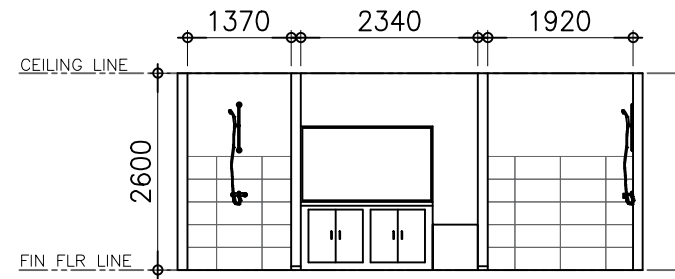

APARTMENT CR FLOOR PLAN
SCALE 1:100

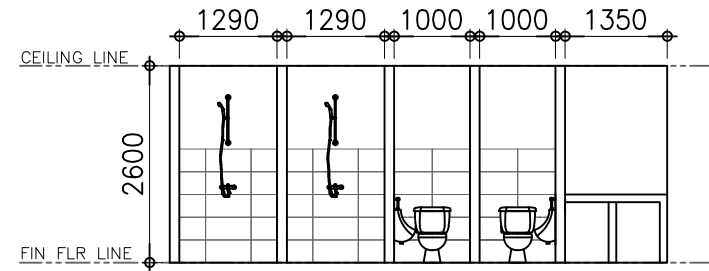

SECTION THRU S-1
SCALE 1:100



SECTION THRU S-2
SCALE 1:100

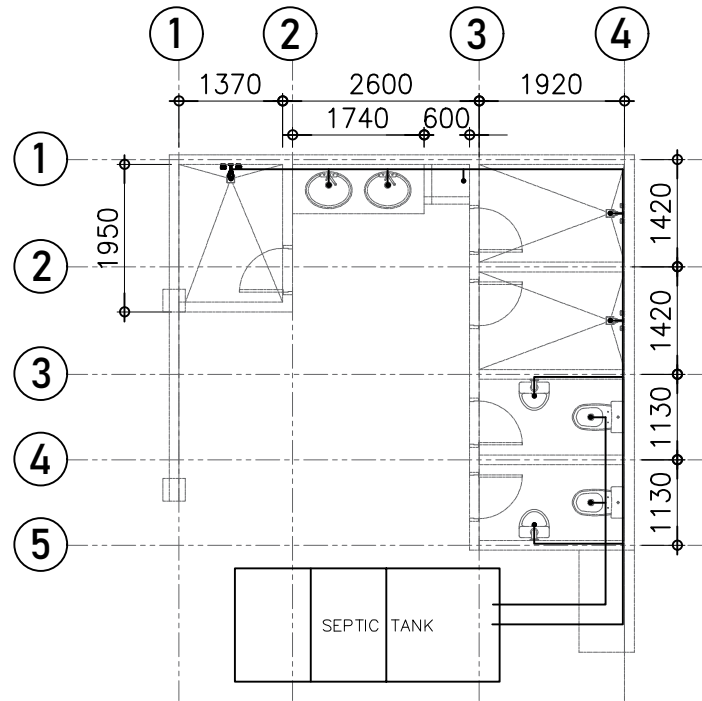

APARTMENT PLUMBING LAYOUT
SCALE 1:100

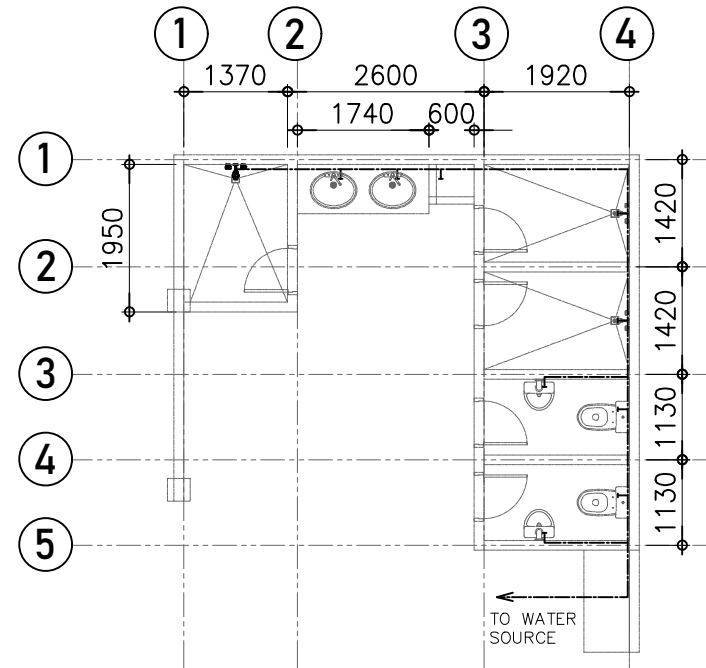

APARTMENT WATERLINE LAYOUT
SCALE 1:100

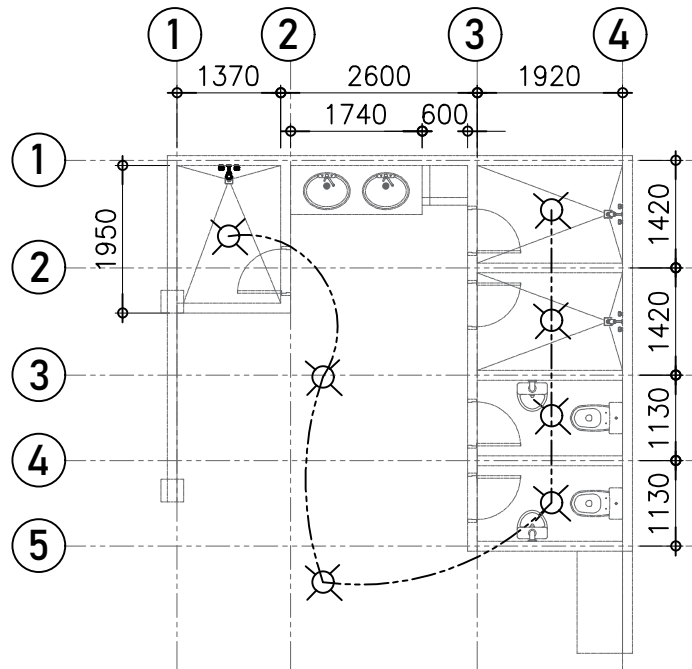

LIGHTING LAYOUT
 SCALE 1:100

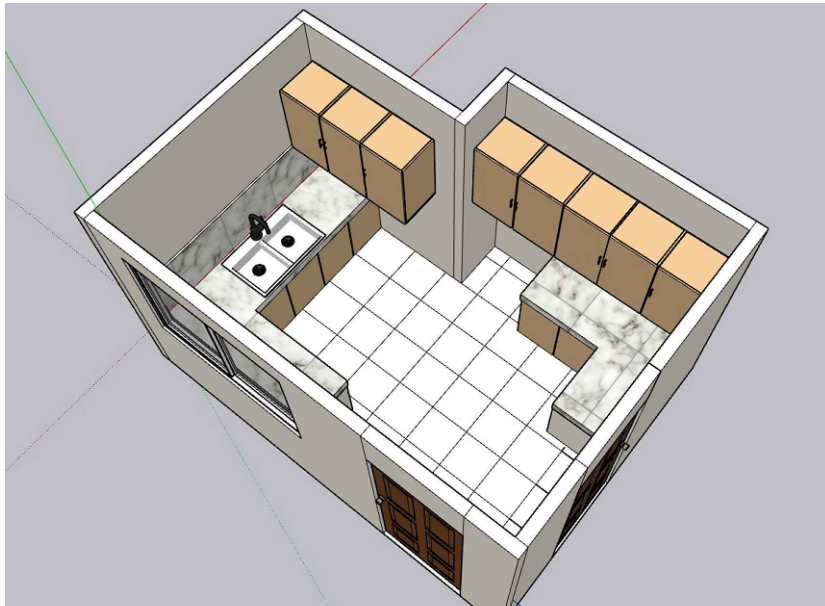

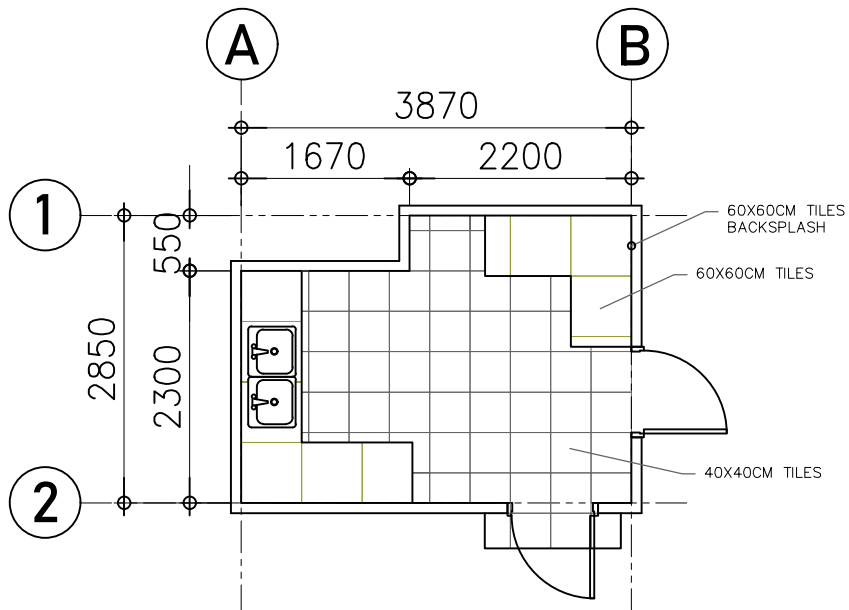

P E R S P E C T I V E
 SCALE NTS



COTTAGE KITCHEN
TILE LAYOUT

SCALE

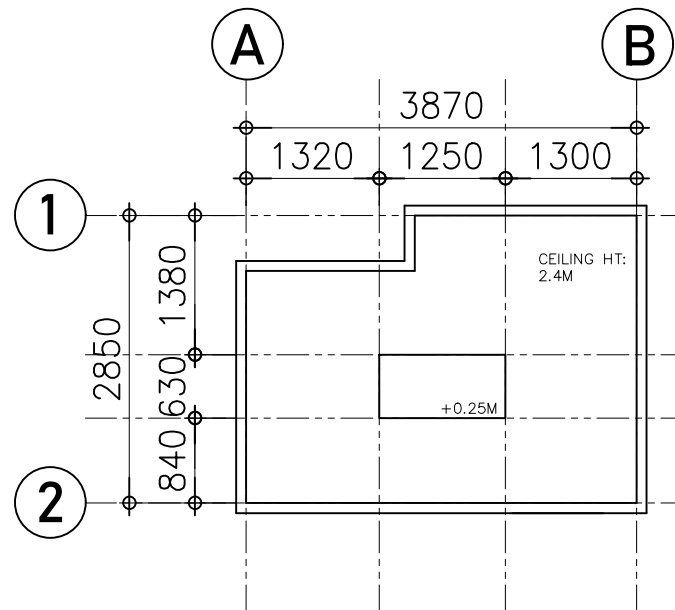
1: 75



COTTAGE KITCHEN
CEILING PLAN

SCALE

1: 75



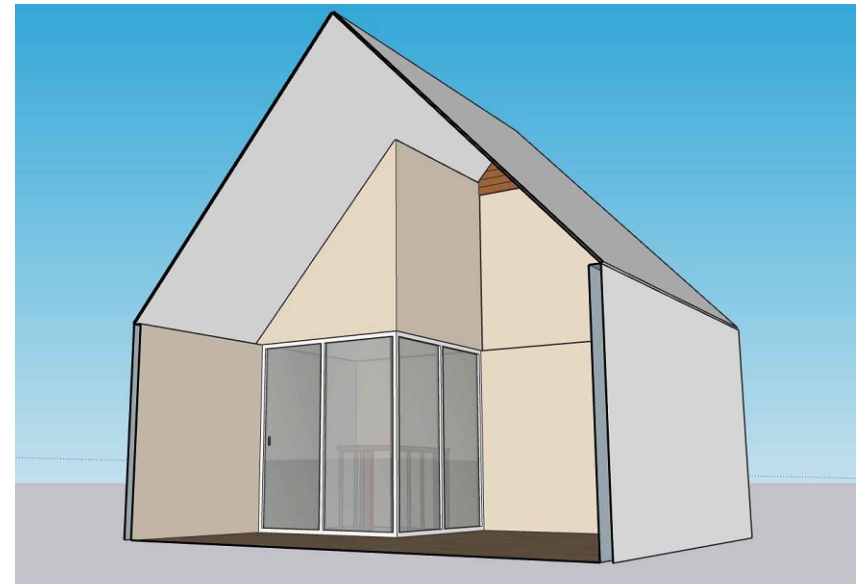
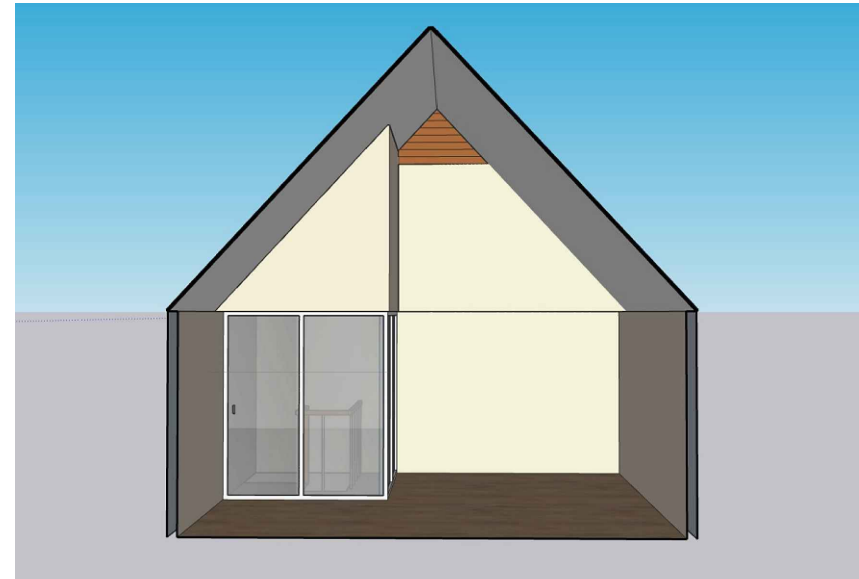
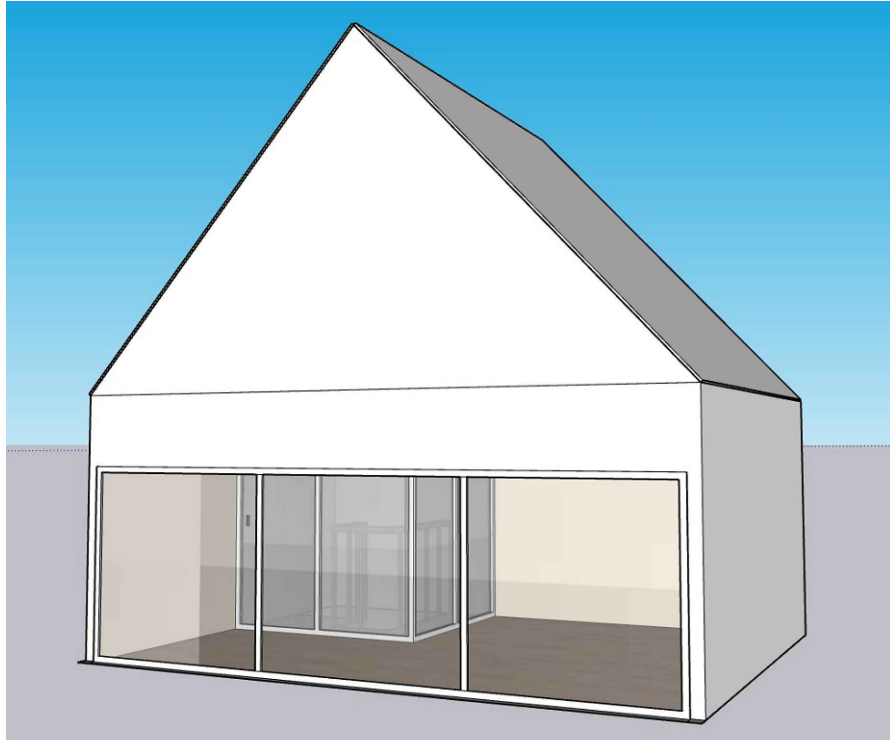

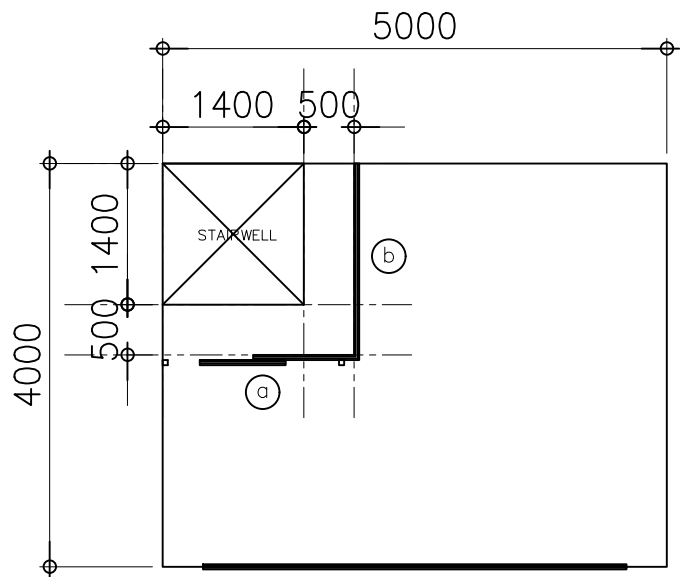

P E R S P E C T I V E
 SCALE NTS



COTTAGE ATTIC GLASS
PARTITION PLAN

SCALE

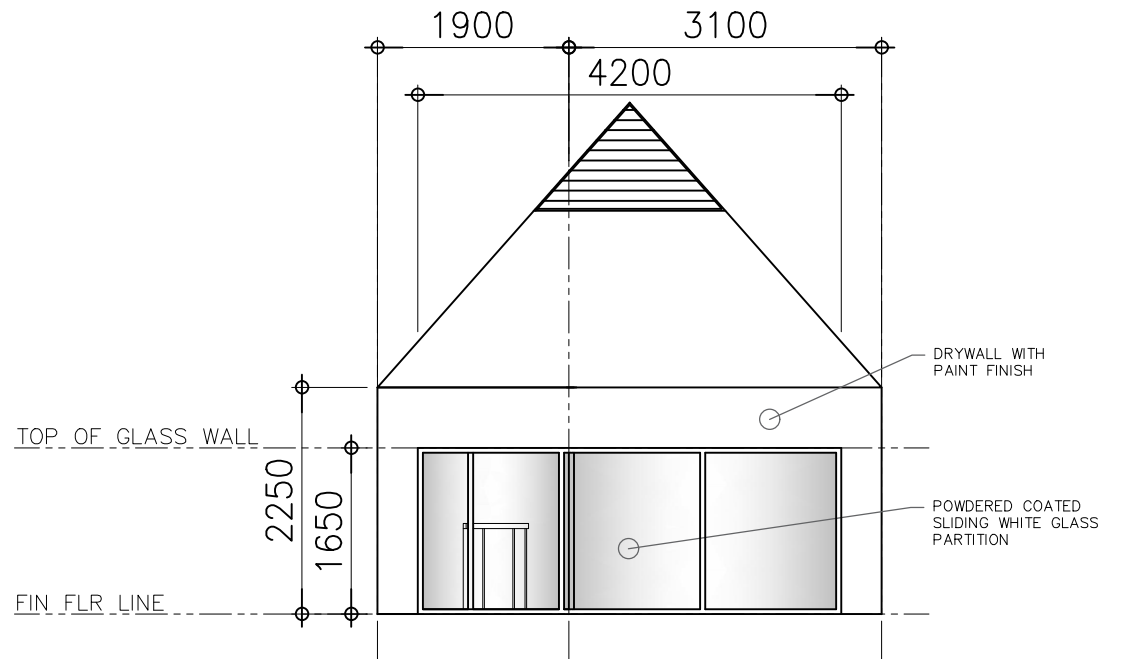
1:75



COTTAGE ATTIC GLASS
PARTITION ELEVATION

SCALE

1:75

PREPARED BY:

APPROVED BY:

PROJECT NAME:

REPAIR AND REHABILITATION OF COTTAGE
(ATTIC)

SHEET CONTENT:

FLOOR PLAN
ELEVATION

SCALE: AS SHOWN

DATE: OCTOBER 10, 2024

SHEET NO.:

2/3

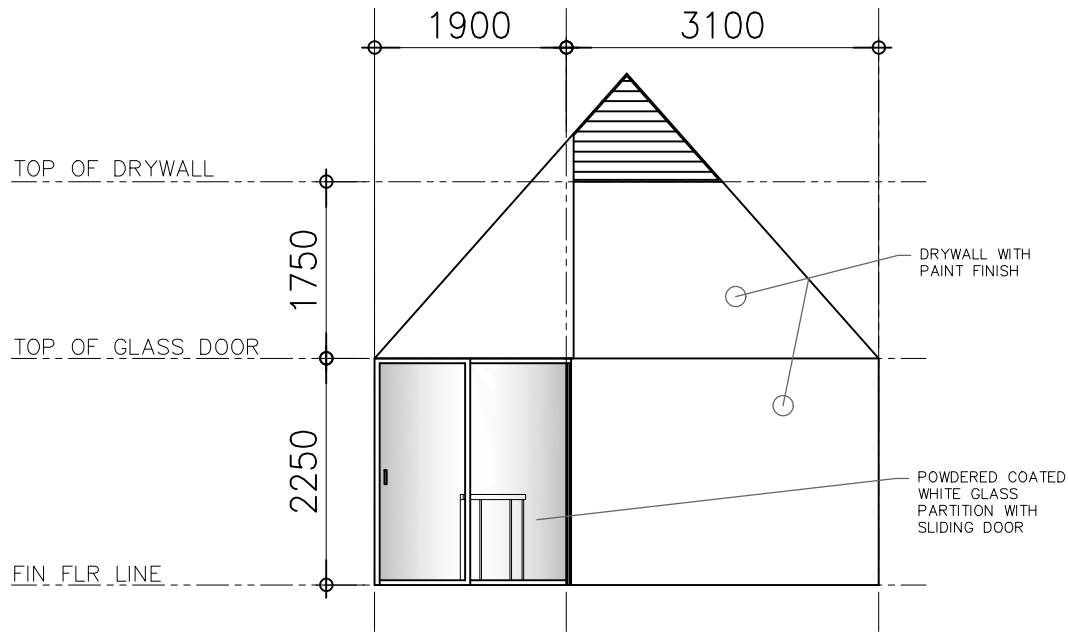

COTTAGE ATTIC GLASS PARTITION SECTION "a"

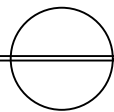

SCALE

1:75

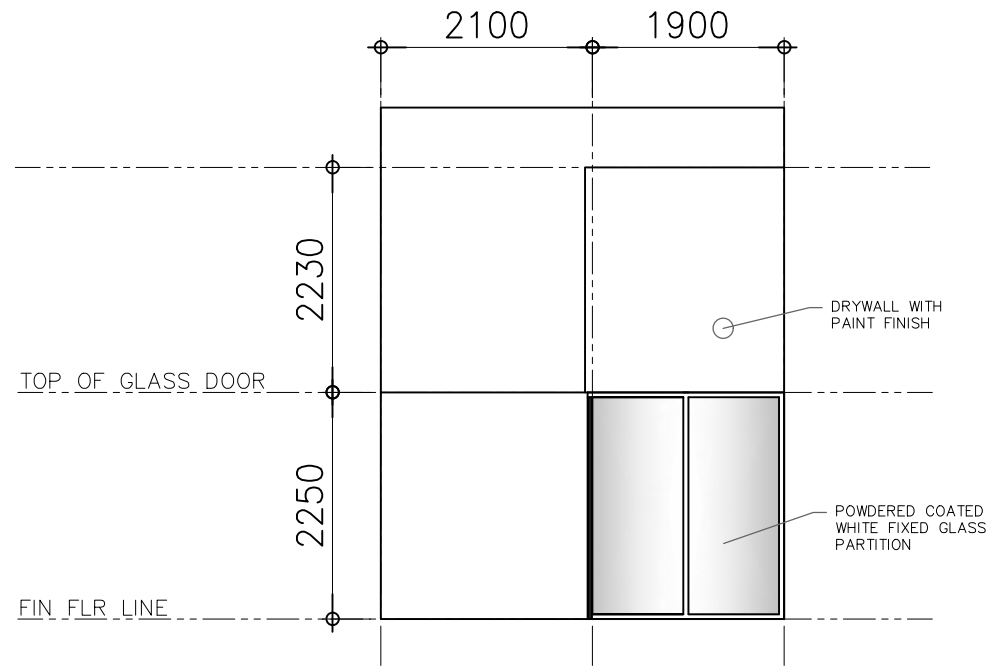

COTTAGE ATTIC GLASS PARTITION SECTION "b"

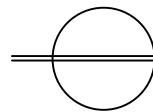

SCALE

1:75

PREPARED BY:

APPROVED BY:

PROJECT NAME:

REPAIR AND REHABILITATION OF COTTAGE
(ATTIC)

SHEET CONTENT:

SECTIONS

SCALE: AS SHOWN

DATE: OCTOBER 10, 2024

SHEET NO.:

3/3

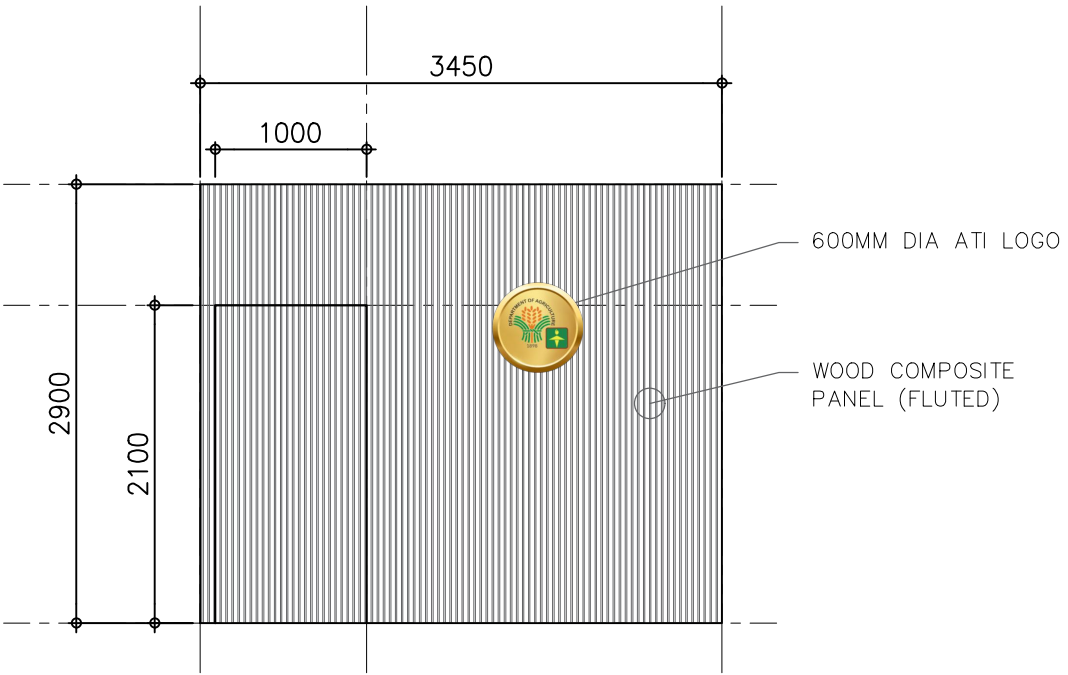
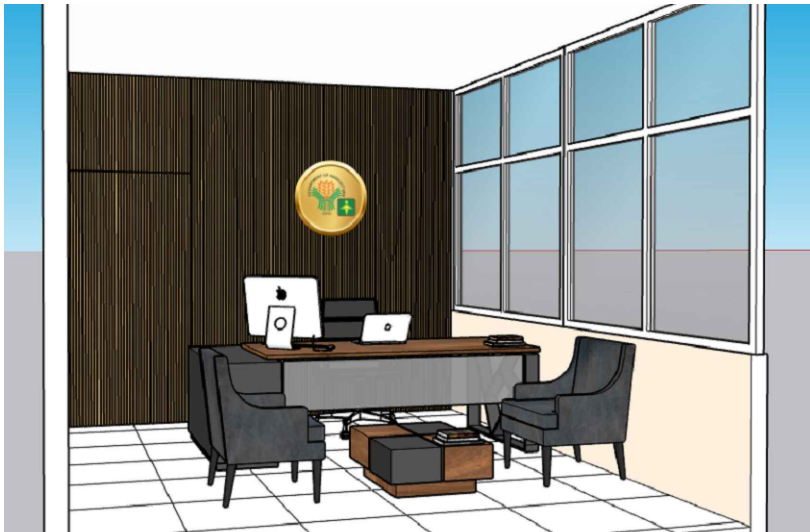
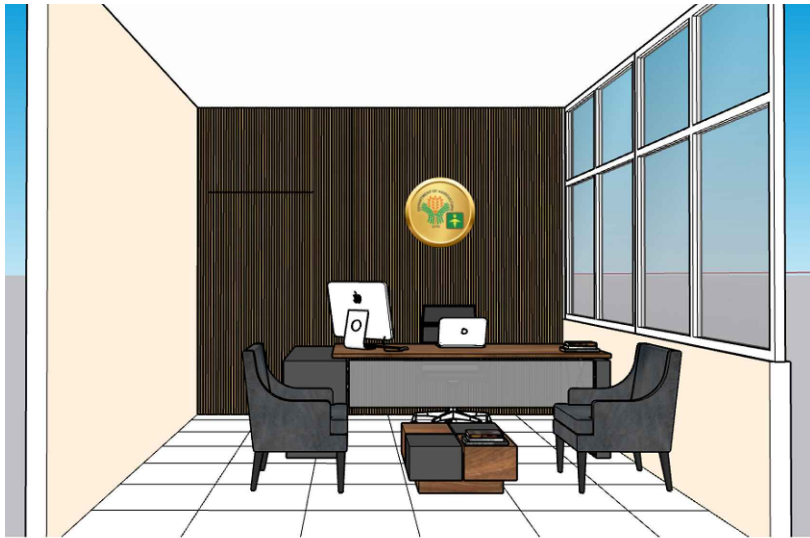

WOOD COMPOSITE
PANEL LAYOUT



P E R S P E C T I V E
SCALE NTS

 Republic of the Philippines Department of Agriculture AGRICULTURAL TRAINING INSTITUTE REGIONAL TRAINING CENTER 1 Regional Training Center, Tebag East, Sta. Barbara, Pangasinan, Tel. No. (075) 522-2265 Satellite Training Center, Dagupan, Pangasinan, Tel. No. (077) 870-1588 Email Address: ati1.dag@da.gov.ph Website: www.ati1.dag.gov.ph www.dpsn.gov.ph	PREPARED BY:	APPROVED BY:	PROJECT NAME:	SHEET CONTENT:	SCALE: AS SHOWN
			REPAIR OF OFFICE	PERSPECTIVE WPC LAYOUT	DATE: OCTOBER 10, 2024
			ATI-RTC1, TEBAG EAST, STA. BARBARA, PANGASINAN		SHEET NO.: 1/1

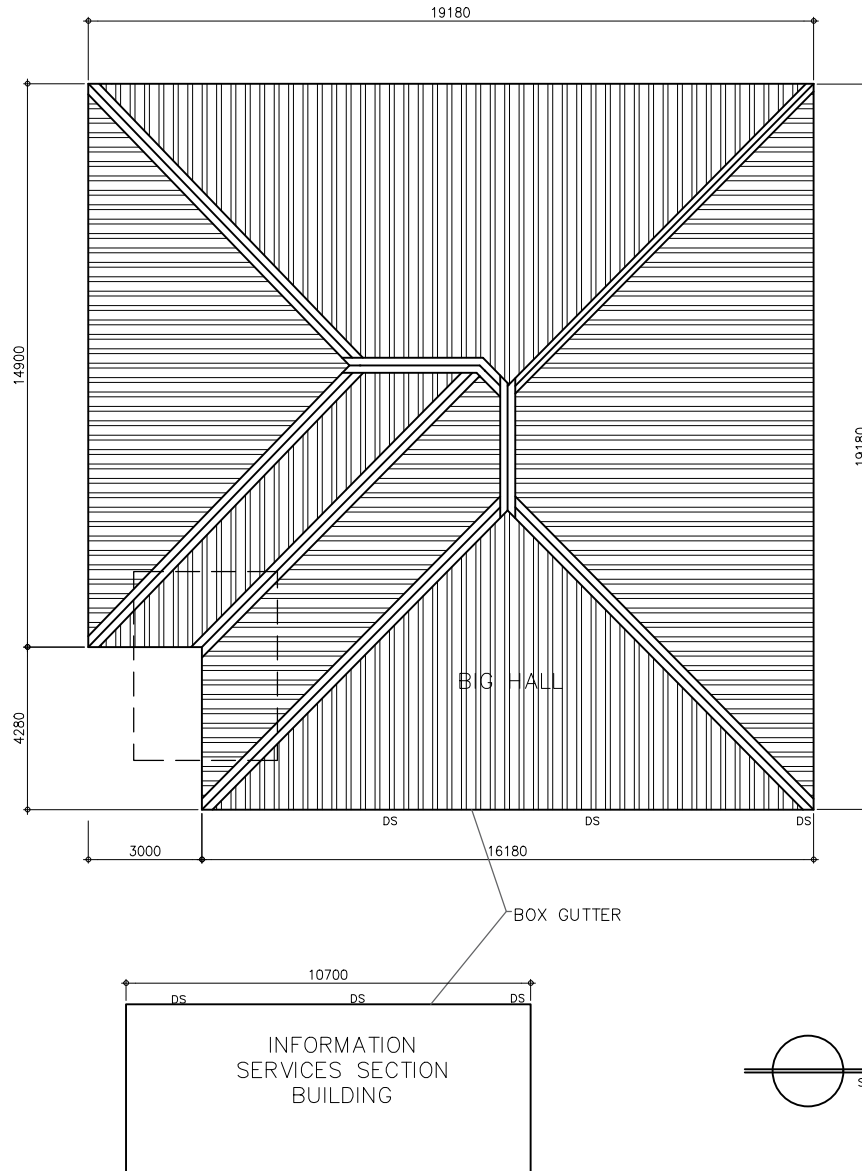

ROOF PLAN
SCALE NTS

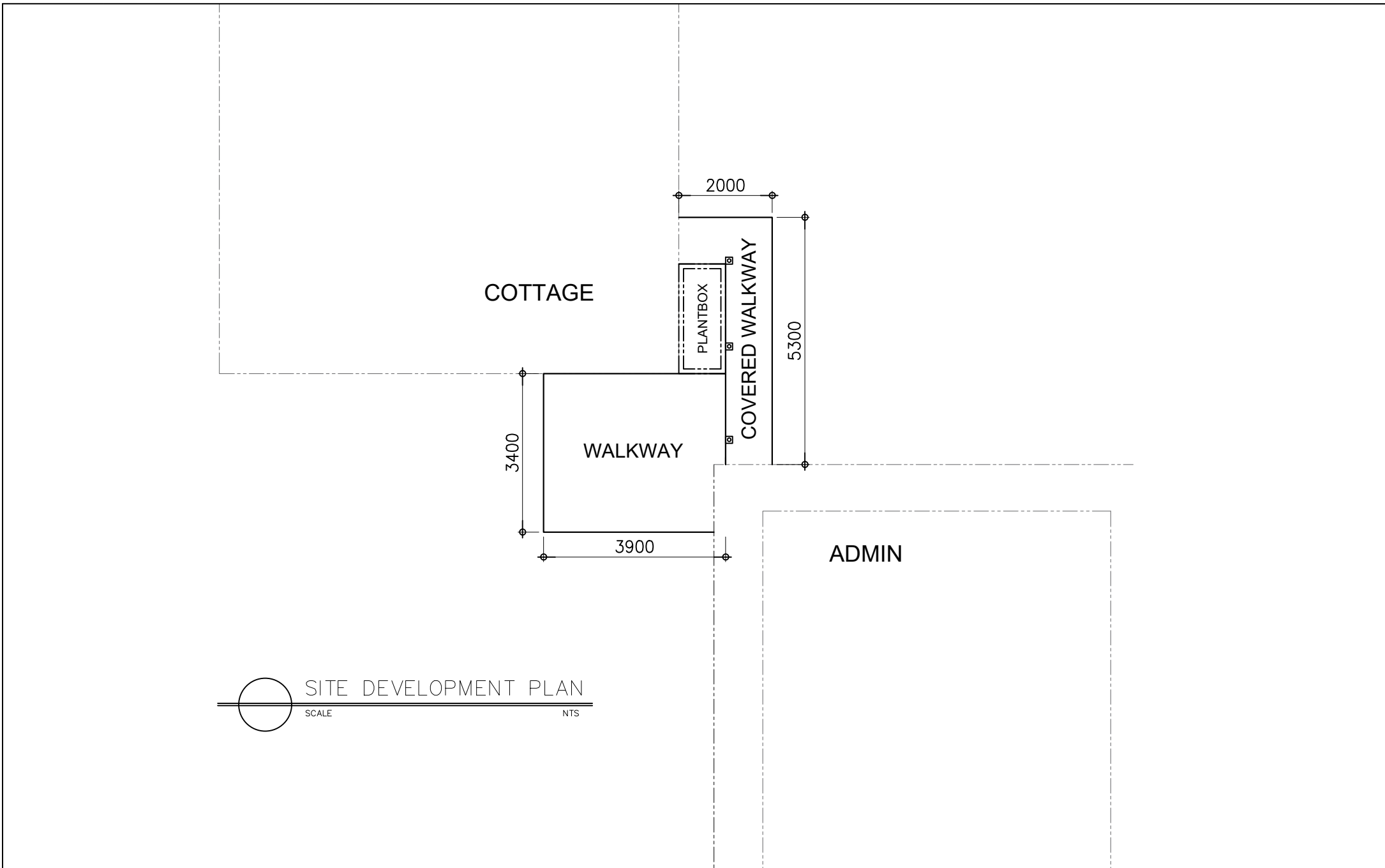

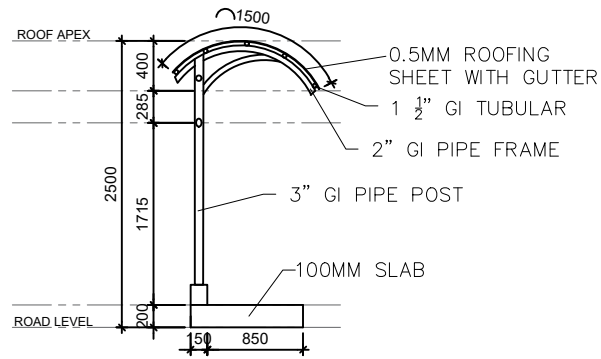

SITE DEVELOPMENT PLAN
 SCALE NTS

 Republic of the Philippines Department of Agriculture AGRICULTURAL TRAINING INSTITUTE REGIONAL TRAINING CENTER 1 Regional Training Center, Tebag East, Sta. Barbara, Pangasinan, Tel. No. (075) 522-2265 Satellite Training Center, Dagupan, Pinaric, Pangasinan, Tel. No. (077) 804-1268 Email Address: r1c1atc@da.gov.ph Website: www.ati-da.gov.ph www.dpsn.gov.ph	PREPARED BY:	APPROVED BY:	PROJECT NAME:	SHEET CONTENT:	SCALE: AS SHOWN
			COVERED PATHWAY AND ROAD CONCRETING	SITE DEVELOPMENT PLAN (ADMIN OFFICE TO COTTAGE)	DATE: AUGUST 05, 2024
			ATI-RTC1, TEBAG EAST, STA. BARBARA, PANGASINAN		SHEET NO.: 1/3

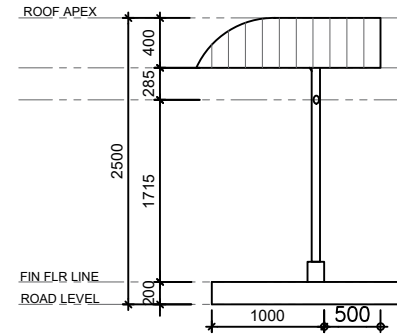

FRONT



REAR

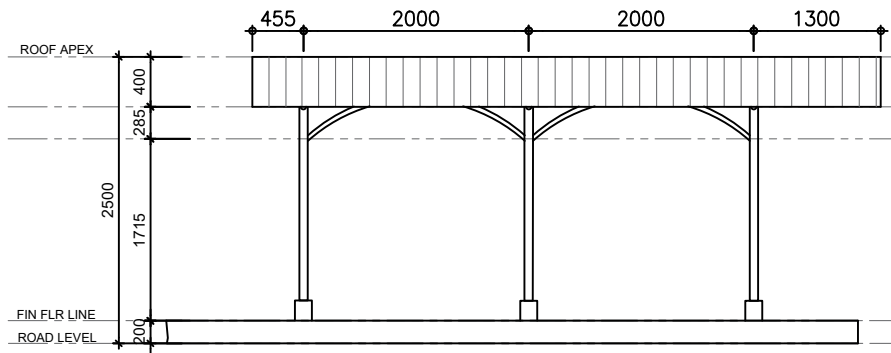

RIGHT SIDE

COVERED PATHWAY
ELEVATION



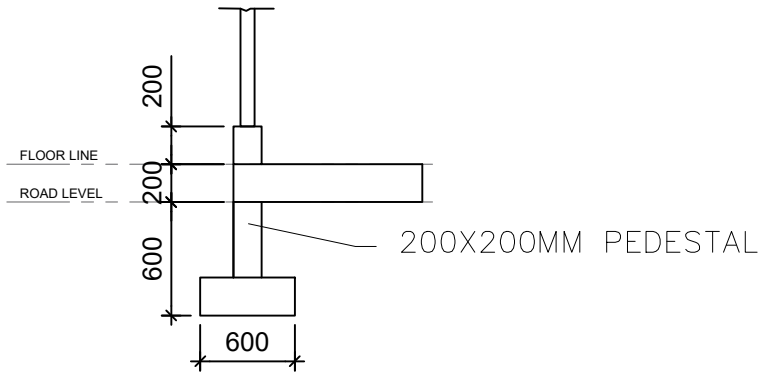

SCHEDULE OF FOOTINGS

MARK	FOOTING SIZE (m)			EXCAV. DEPTH (M)	REINFORCEMENTS		REMARKS
	L	W	t		ALONG 'L'	ALONG 'W'	
F-1	0.60	0.60	0.20	0.60	4-12 Ø	4-12 Ø	ISOLATED



COLUMN SCHEDULE

